

Medical

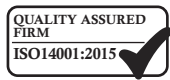

**GM350** For complete destruction of General Medical (GM) waste.  
Highly effective top loading incinerator for secure disposal of sharps, general medical, clinical, and pathological waste.

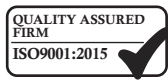

The GM350 is highly flexible compact incinerator. Designed for complete destruction of general medical waste. Manufactured to deliver optimum results through retaining maximum heat within the main chamber. Constructed with a multi layered 180mm brick refractory placing our machines at the forefront of quality.

The GM350 has a 0.59m<sup>3</sup> chamber volume, making it ideal for smaller hospitals and clinical practices. Utilising pulse firing burners, our GM range of incinerators are up to 40% more efficient than other machines, saving fuel and money. This machine perfect for laboratories and clinical centres.

Machine Specification	
External L x W x H (mm)	3725 x 2210 x 1940/3825
Internal L x W x H (mm)	1320 x 720 x 700
Chamber Volume (m <sup>3</sup> )	0.59
Weight (approx tonnes)	3.1
Max Load Capacity (kg)	350
Nominal Burn Rate UK* (kg/hr)	<50
Burn Rate [Export Only]* (kg/hr)	50 - 75
Thermal Capacity (kW)	260
Power Supply 50/60 hz	220 - 250v
Door Aperture	1265 x 690
Control Panel	AI or PLC
Fuel Types	Diesel, LPG, N-Gas
Insulation Board	25mm Superwool
Insulation Fire Brick	Grade E23
Fire Brick (Alumina)	42.5%

\*We reserve the right to change the specification, dimensions and quality of materials from time to time, so long as the alteration is minor or an improvement to the said product.

### Primary Chamber

- Pre-cast block impact zone protecting refractory lining during loading.
- Heavily insulated internal brick refractory, constructed along an interlocking systems to ensure maximum strength and resilience.
- Premium grade high alumina content refractory brick work delivering optimal thermal retention.
- Top loading counter balanced insulated access lid.
- Temperature controlled waste ignition burner automatic on-off, complete with internal air fans.

### Secondary Chamber

- Fully insulated internal refractory lining. Constructed from high grade low thermal mass insulation.
- Temperature controlled Secondary chamber burnout burner with automatic on-off control, complete with internal air fans.
- Integrated combustion burner air fans automatically controlling distribution to designated areas.
- Temperature sensor mounting point at the top of the chamber, ensuring the chamber reaches the required 1100°C minimum, with a 2 second retention time.

### Waste Type

	Clinical Waste	✓
	Treated Waste	✓
	Anatomical Waste	✓
	Cytotoxic & Cytostatic Waste	✓
	Offensive/Hygiene Waste	✓
	Medicinal Waste	✓
	Domestic (municipal) Waste	✓

Medical



# GM350

For complete destruction of General Medical (GM) waste.

## Waste Loading and De-Ashing

The GM range of incinerators are designed for top loading directly into the primary chamber. Loading can be manual or mechanically through digger or hydraulic bin tippler. To be loaded no more than once per day prior to operation. The incineration process will reduce the waste to approximately 3% volume, ash. The ash should be removed before the following waste is loaded to ensure optimum burn rates. Optional de-ashing doors are available.

## The Addfield Difference

- Pre-Fabricated 8mm & 10mm robust mild steel casing, seam welded and suitably stiffened/ braced where necessary.
- Optimised loading chamber for maximum operational capacity.
- Lightweight resilient refractory fibre insulated lid, providing a tight seal, giving excellent thermal efficiency.
- Counterweighted loading chamber lid for ease of use.
- Primary chamber lining thickness 180mm rated up-to 1650°C
- Premium paint finish - Steel structures are painted using a two pack high grade paint system.
- Multi-layered refractory lining using fire bricks and insulation bricks, improving thermal efficiency.



## Additional Operation Equipment



### Bin Tipper

The Bin Tipper unit empties waste within the bin using a unique electro-hydraulic mechanism that can lift and tip more than 150kg. Hands free loading ensures operators safety, when dealing with hazardous waste.



### Fuel Tank

Allowing you to operate the incinerator in all locations as well as providing a backup to your traditional supply. Available in 1000 to 5000 litre capacity. Fuel can be safely stored and monitored in close proximity to your incinerator.



### Venturi System

The Venturi is an advanced flue gas treatment system designed to further reduce dust, acid gasses, dioxins and furans. Highly effective, the venturi is widely regarded as the leading treatment system in its field.



# Addfield Intelligent PLC Controller

Simple to operate adaptive control system for achieving optimal results from your machine.

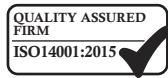
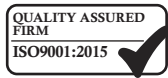

## Controller Features

The Addfield PLC Controller has been developed to provide you with a simple yet effective operational process. Designed around a touch screen HMI interface, and independent burner control buttons and switches.

The touch screen interface provides all of your essential operations at the press of a finger. Having pre-loaded programmes optimised for your individual requirements, waste type and operating regime.

Giving you instant access to live temperature readings for the primary and secondary chambers and remaining burn time to enable you to manage your incineration process more efficiently.

Simple to install with a plug and play interface which enables straight forward installation and maintenance.

Built in data-logging to automatically records you usage, timings and temperatures achieved. Archives all essential which is able to be exported to Excel through the removable USB drive.

Complete with the addition of an emergency stop button to instantly cancel all operations.



## Key Features

- Plug and play design
- Zone ramp sequence multi zone controller.
- Incoming and outgoing cable terminations.
- Burner control gear.
- Interface relays and contractors.
- Temperature indication and control of the primary chamber.
- Temperature indication and control of the secondary chamber.
- Plant status indicators.
- Cycle status indicators.
- Fault status indicators.
- Operator interface.
- Data-logging.
- Schematic overview.
- USB Port.
- Emergency Stop button.

\*We reserve the right to change the specification, dimensions and quality of materials from time to time, so long as the alteration is minor or an improvement to the said product.

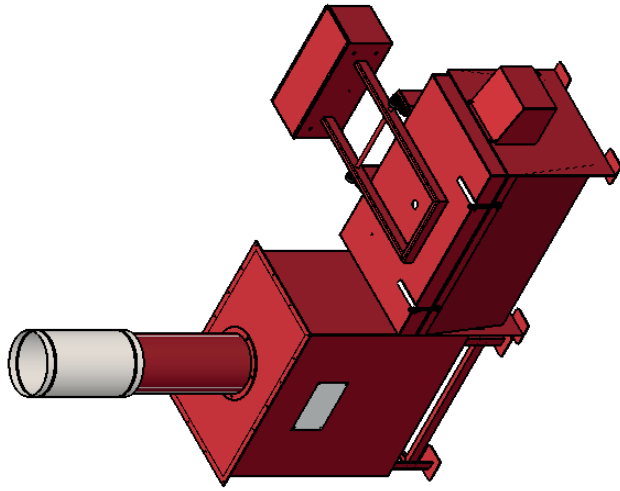

ISOMETRIC VIEW

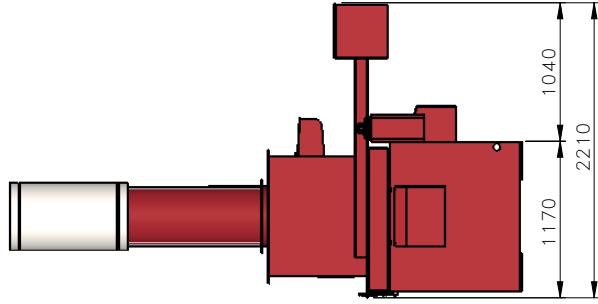

SIDE VIEW

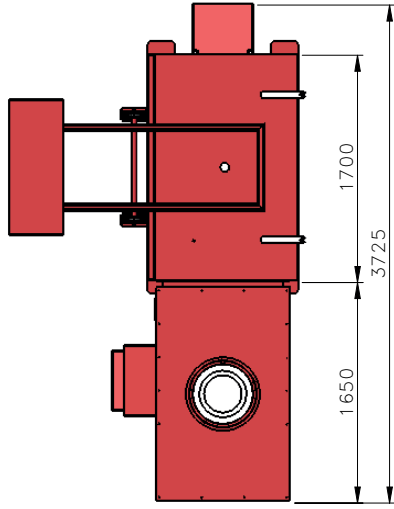

PLAN VIEW

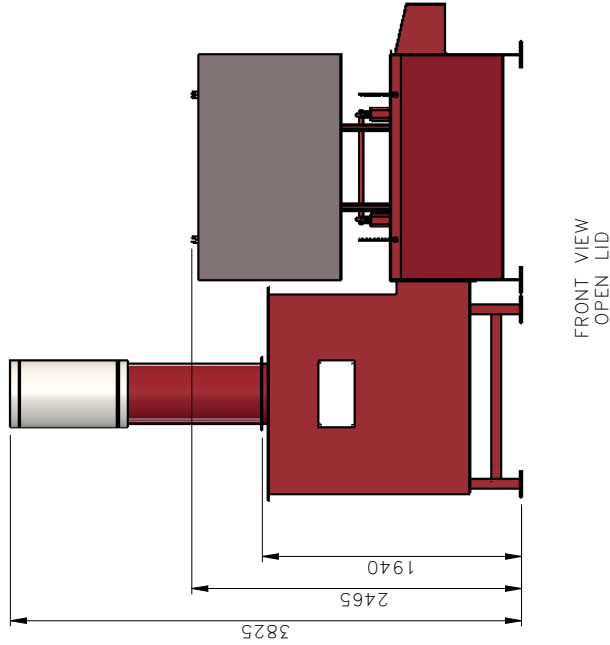

FRONT VIEW  
OPEN LID

DATE	DRAWN	CHECKED	APPROVED	DATE	DRAWN	CHECKED	APPROVED	DATE	DRAWN	CHECKED	APPROVED	DATE	DRAWN	CHECKED	APPROVED
D				C				A				01/05/2019	KJ		
COMMENTS															
COMMENTS															
COMMENTS															

This drawing and any information or descriptive material contained herein is the confidential and proprietary information of Addfield Environmental Systems LTD. It is to be used for the purpose intended and MUST NOT BE REPRODUCED, COPIED, LOANED in whole or part or used for any purpose without the written permission of Addfield Environmental Systems.

DRAWING No.		REV
38-001-2		—
SHEET No.	1 OF 1	SCALE: 1:40
GM350 GA		A3

 THIRD ANGLE PROJECTION (UNLESS STATED OTHERWISE)	TOLERANCES (UNLESS STATED OTHERWISE) WHOLE NUMBERS ±1.00 1 DECIMAL PLACE ±0.10 2 DECIMAL PLACE ±0.05 ANGLES ±0.50°
MATERIAL: N/A	FINISH: N/A
WEIGHT: 3100kg	

**Incinerate • Cremate**  
 Addfield Environmental Systems LTD  
 Unit 9, Zone 4  
 Burntwood Business Park  
 Staffordshire  
 WS7 3XD  
 T: +44 (0)1543 571 280  
 F: +44 (0)1543 571 173  
 E: sales@addfield.com  
 www.addfield.com  
 DRAWN BY: KJ      DATE CREATED: 01/05/2019  
 PROJECT:

STANDARD—GM350

TITLE: GM350 GA